

16" Plenum Box  
For A\*Mist 40TF  
(JT or K&B)

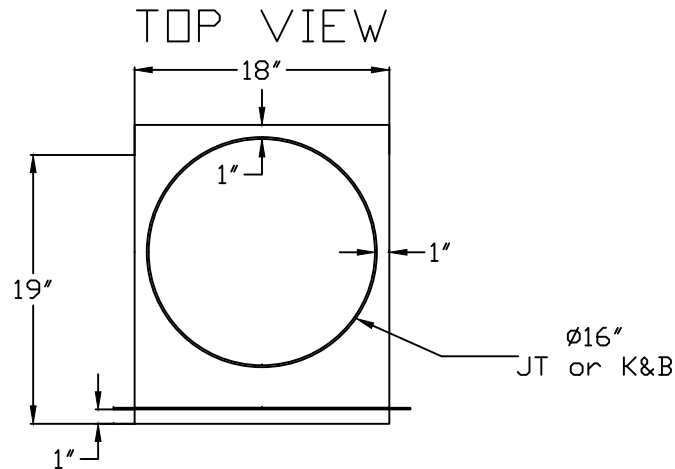

- NOTES:  
 A) MATERIAL: 18 GA. GALV.  
 B) ALL SEAMS WELDED  
 C) Use standard bolt hole pattern with 7/16" Holes

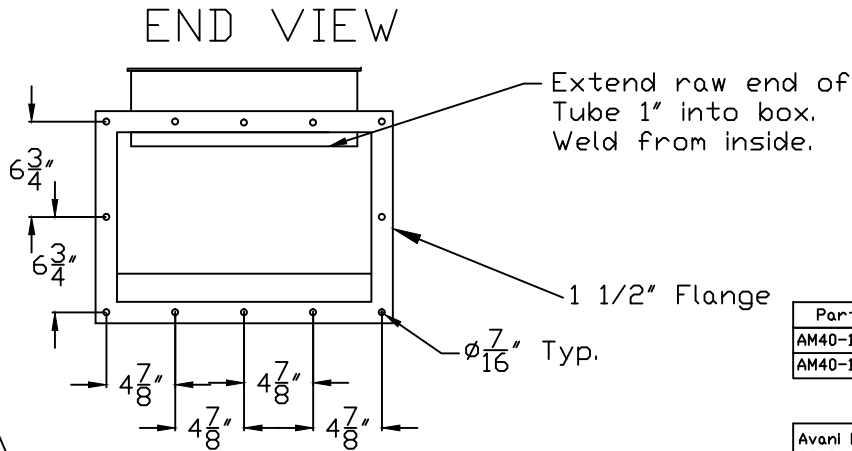
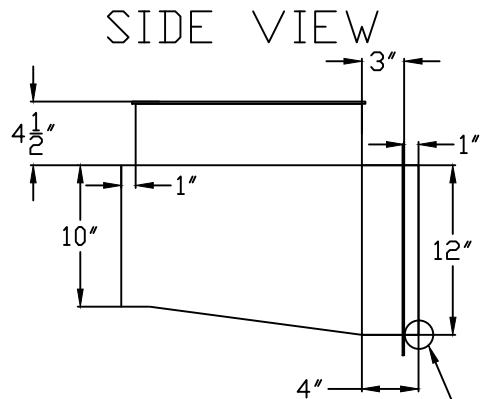

NOTE: WELD ALL CORNERS ON BOTTOM INSIDE THE PLENUM!!!!

Part No:
AM40-16-JT-PB
AM40-16-KB-PB

Avani Environmental Intl. 95 Cypress Drive Youngsville, NC 27596 P# 919-570-2862 F# 919-570-2863	<b>Avani</b>
Project: Absolent Plenum, Boxes	
Drawing: AM40-16-PB	
Date: 4/22/15	Drawn by: DJT
Sheet No: 1 of 1	Rev.: A