



USER'S MANUAL IN ORIGINAL Oil Mist Filter

A•mist^{10C}

A•mist^{10C} HEPA



A•mist^{10C}



Absolent

1 BASIC INFORMATION

1.1 INTRODUCTION

This manual contains all necessary information about safety, commissioning and maintenance. For more information regarding installation, please see separate installation manual.

This product is produced and designed in accordance with applicable EC directives. To preserve this status, this unit must be installed, repaired and maintained by skilled personnel and genuine spare parts must be used. For advice when technical service or spare parts are needed, contact Absolent or your nearest authorized dealer. You will find details on who to contact under the heading: "Technical Support".

1.2 RANGE OF APPLICATION

The A•mist^{10C} filter unit is designed for cleaning air containing oil mist* only. Use of the filter unit for other applications is not permissible, unless the manufacturer guarantees its proper function. If the A•mist filter unit is used in applications where there are traces of graphite, lead or chrome, you might need to clean or change filter cassettes more often.

* From cutting fluids like emulsion, synthetical oil or/and mineral oil.

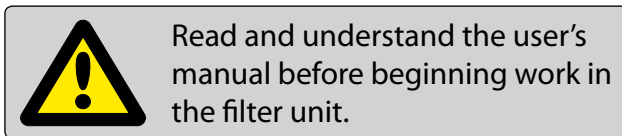

1.3 CONTENTS:

1	BASIC INFORMATION.....	2
1.1	Introduction	2
1.2	Range of Application.....	2
1.3	Contents.....	2
2	APPROVED TO CE DIRECTIVES, UL AND CSA STANDARDS.....	3
3	LIST - WARNING SIGNS.....	3
4	SAFETY PRECAUTIONS.....	4

1.3 CONTENTS CONT'D.:

5	OPERATION / DESIGN	5
5.1	Function A•mist ^{10C}	5
5.2	Function A•mist ^{10C} HEPA	5
6	TECHNICAL DATA	6
7	ELECTRICAL CONNECTIONS	7
7.1	General.....	7
7.2	Electrical connection of the fan motor for direct start	7
8	STARTING THE FILTER UNIT FOR THE FIRST TIME	7
8.1	Inspections before initial start	7
9	CARE/MAINTENANCE	8
9.1	General.....	8
9.2	Service Schedule.....	8
10	ELECTRONIC PRESSURE MANOMETER.....	9
10.1	Function description	9
10.2	Pressure settings electronic manometer...	9
11	HANDLING THE FILTER CASSETTES	10
11.1	General	10
11.2	Filter cassette positioning	10
11.3	Instructions for replacing filter stage 1	11
11.4	Instructions for replacing HEPA filter	12
11.5	Worn out filter cassettes	13
11.6	To clean filter cassettes	13
12	ACCESSORIES	14
12.1	Wall mounting bracket.....	14
12.2	Ceiling hung	14
12.3	Floor stand	14
12.4	Outlet duct connection.....	14
12.5	Extension hood for after-assembly of HEPA	15
12.6	Carbon filter cassette	15
12.7	Liquid trap options	16
12.7.1	Liquid trap - hose.....	16
12.7.2	Liquid trap - PVC	16
12.7.3	Liquid trap - steel bucket.....	16
12.7.4	Liquid trap - receptacle	16
12.8	Spray system	17
12.9	Motor protection	17
12.10	Frequency converter	17
13	FAULT TRACING.....	18
14	CHECKING THE FAN'S DIRECTION OF ROTATION	19
15	ABSOLENT WARRANTIES.....	19
16	SPARE PARTS.....	20
17	TECHNICAL SUPPORT.....	20
18	EC DECLARATION OF CONFORMITY	21

2 APPROVED TO CE-DIRECTIVES, UL AND CSA STANDARDS

The A•mist^{10C} and A•mist^{10C} HEPA products are approved to:

Machine directive	2006/42/EG
Electromagnetic Compatibility (EMC)	2004/108/EG
Low Voltage Directive (LVD)	2006/95/EG

EC Declaration of conformity, see chapter 18.

All electrical components are UL approved.
The electrical motor is CSA approved.







The CSA approval is solely applicable to the electrical motor.

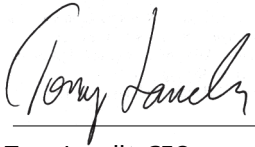





Tony Landh, CEO



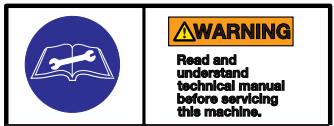

Absolent
Absolent AB
Kartåsgatan 1
531 40 Lidköping
Sweden
2009-12-28

3 LIST - WARNING SIGNS

	<p>WARNING - READ THE USER'S MANUAL Read and understand the user's manual before beginning any work in the filter unit. This sign is located on the right-hand side of the filter unit.</p>
	<p>WARNING - DANGEROUS VOLTAGE All electrical work must be carried out by qualified electricians. This sign is located next to the control cabinet.</p>
	<p>WARNING - ROTATING PARTS Consider that the filter unit/and pump can be started up by a timer, remote control or by a metal working machine connected to it. This sign is located on the right-hand side of the filter unit.</p>
	<p>WARNING - RISK OF INJURY Caution, the filter unit can contain fluids dangerous to health. Refer to the product sheet for the fluids in question before handling. This sign is located on the right-hand side of the filter unit.</p>

4 SAFETY PRECAUTIONS

TYPE OF WARNING	WARNING TEXT
 Danger	<p>WARNING - HAZARDOUS VOLTAGE! The filter unit works with a high electrical voltage. The electrical installation must be performed by qualified electricians. Disconnect the power supply to the filter unit before it is opened and/or before starting work on the filter unit.</p> <p>WARNING - DO NOT CONNECT THE FILTER UNIT TO EXPLOSIVE GASES! Do not connect the filter unit to processing machines that can bring about an explosion risk. Furthermore, the filter unit must not be connected to media that are highly inflammable without preventative measures being taken to stop the spread of the explosion or fire to the filter unit.</p>
 Skilled personnel	<p>CAUTION - READ AND UNDERSTAND THE USER'S MANUAL! Read and understand the user guide before working on the filter unit.</p> <p>CAUTION - QUALIFIED PERSONNEL ONLY! All work concerning transport, installation and maintenance must be performed by qualified personnel.</p>
 Risk of personal injury	<p>RISK OF TRAPPING INJURY! Do not insert your hand into the filter unit when the fan is running. Do not wear loosely hanging clothing near the fan when operational. These can be sucked into the fan or get caught.</p> <p>HEAVY PRODUCTS! Filter cassettes are heavy. Check the current weight of the filter cassette before handling. Weight details can be found on the filter cassette's rating plate and under heading 11 "Handling the filter cassettes". Lifting equipment or the like must be used during service and inspection work above the ground.</p> <p>RISK OF SLIPPING! Keep the floor clean. Remove oil spill to prevent injury due to slipping.</p> <p>HIGH NOISE LEVELS! If the noise level at the control panel/workplace exceeds 75 dB(A) ear protection must be worn.</p> <p>DANGEROUS FLUIDS! Use requisite personal safety equipment with all types of service work, as the filter unit can contain liquids dangerous to health. Refer to the product sheet for the liquids in question before handling.</p> <p>CAUTION WHEN RECIRCULATING AIR BACK INTO THE BUILDING! Note that in its standard design the filter unit does not separate gas molecules.</p>

5 OPERATION / DESIGN

5.1 FUNCTION A•mist^{10C}

Contaminated air is sucked into the inlet on the side of the assembled unit. For this version of the A•mist^{10C} unit, the filtering process occurs in one stage only. There are different filter cassettes to suit different applications available. Depending on the type of the chosen cassette, the constant collecting efficiency varies from 83 up to 93%. Thanks to the continuous draining of the filter cassette, the unit can be operated without interruption 24-7. The returned oil is collected at the bottom of the filter for recycling.

The air is then extracted through the fan, after which it is usually clean enough to be returned directly to the premises.

An electronic manometer indicates when the filter cassette needs to be washed or replaced. A signal from the electronic manometer can also be transferred from the unit to somewhere externally.

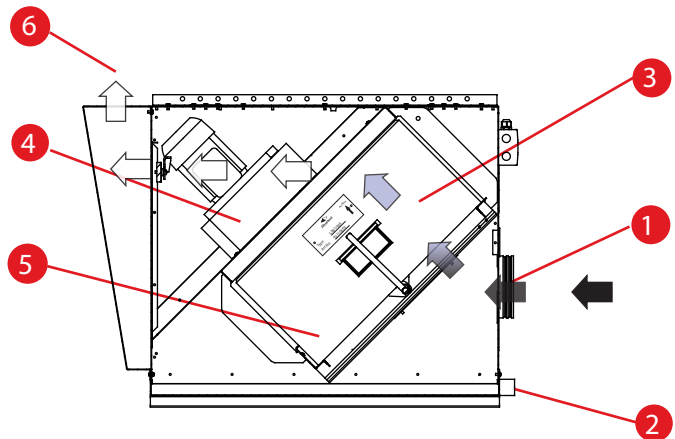

1. Inlet, pipe connection
2. Return oil pipe
3. Filter stage 1
4. Fan
5. Electrical manometer (in the door)
6. Outlet

5.2 FUNCTION A•mist^{10C} WITH HEPA

Contaminated air is sucked into the inlet on the side of the assembled unit. For this version of the A•mist^{10C} unit, the filtering process occurs in two stages. Thanks to the continuous draining of the Absolent filter cassettes, the unit can be operated without interruption 24-7. The returned oil is collected at the bottom of the filter for recycling.

The air is then extracted through the fan, after which it is filtered once more in an HEPA H13 cassette. The HEPA cassette offers a guaranteed and consistent collecting efficiency of 99.99% arresting mpps (most penetrating particles approx. 0.14 μm). The air is now usually clean enough to be returned directly to the premises.

An electronic manometer indicates when the filter cassette needs to be washed or replaced. A signal from the electronic manometer can also be transferred from the unit to somewhere externally.

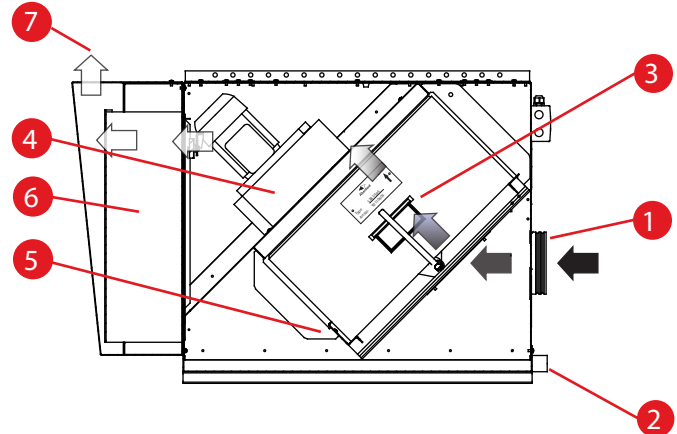

1. Inlet, pipe connection
2. Return oil pipe
3. Filter stage 1
4. Fan
5. Electrical manometer (in the door)
6. HEPA H13 cassette
7. Outlet

6 TECHNICAL DATA

A•mist^{10C}

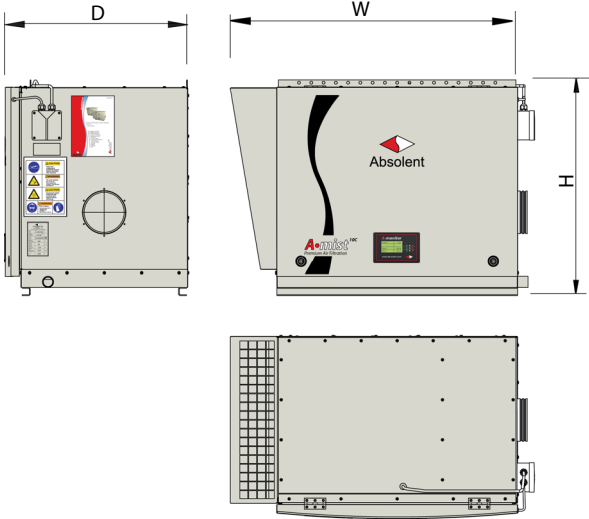

A•mist^{10C} HEPA

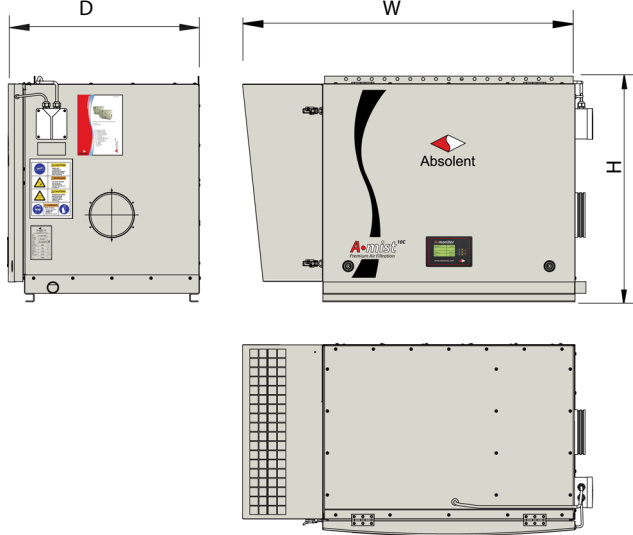

		A•mist ^{10C}	A•mist ^{10C} HEPA
Height (H)	[in/mm]	31.8 / 807	31.8 / 807
Width (W)	[in/mm]	42.4 / 1077	46.9 / 1190
Depth (D)	[in/mm]	27.0 / 684	26.9 / 684
Std. inlet connection	[in/mm]	6.3 / 160	6.3 / 160
Std. return oil connection	[in]	1 1/4"	1 1/4"
Weight with dry filters	[lbs/kg]	287 / 130	331 / 150
No of filter cassettes			
Absolent filters	[Pcs.]	1	1
HEPA Filters	[Pcs.]	-	1
Performance			
Max. airflow	[cfm/m ³ /h]	590 / 1000	1000
Available pressure drop	[Pa]	200	100
Noice level (1m in front of the filter unit)	[dB(A)]	65	60

7 ELECTRICAL CONNECTIONS



WARNING - DANGEROUS VOLTAGE
All electrical work must be carried out by qualified electricians.

7.1 GENERAL

The Absolent filter units are as standard equipped with wired cables from the fan to the terminal blocks on the side of the filter unit. For the warranty to apply, a qualified person must carry out all the electrical wiring in accordance with local regulations. If the filter unit is equipped with extra electrical equipment, this equipment must be wired according to the wiring diagram supplied. The Absolent oil mist and oil smoke filter unit can be customized to meet your needs. The range of accessories includes starting equipment and other electrical peripheral equipment. The most common accessories are described under the heading "Accessories".

7.2 ELECTRICAL CONNECTION OF THE FAN MOTOR FOR DIRECT START

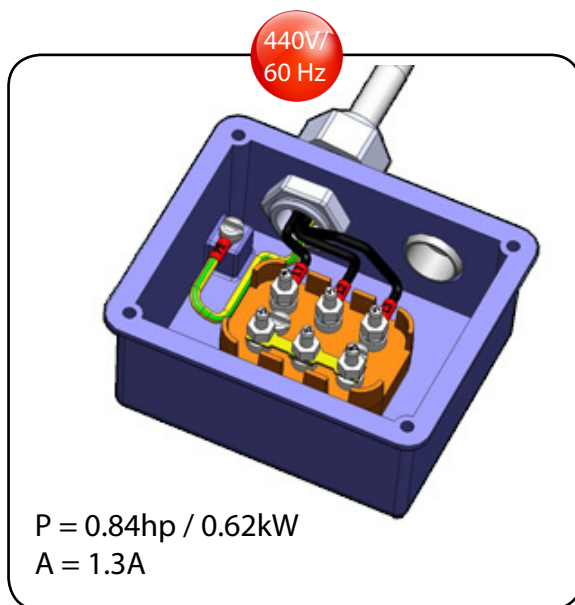

Electrical data can be read from the rating plate on the right-hand side of the filter unit.

8 STARTING THE FILTER UNIT FOR THE FIRST TIME

8.1 INSPECTIONS BEFORE INITIAL START

- Check that the filter cassettes are properly tightened.
- Check that the service doors are closed and secured.
- Check that the air outlet is unblocked.
- Check the fan's direction of rotation (see 13).

9 CARE / MAINTENANCE

9.1 GENERAL

Preventive maintenance and regular service extend the life span and ensure that the filter unit maintains its performance.

To facilitate inspection of the filter cassette status, Absolent supplies an electronic pressure monitor, A•monitor, as standard equipment. It is positioned on the front of the filter unit as shown below:



More information about the electronic pressure monitor can be found in chapter 10.

9.2 SERVICE SCHEDULE

Action	Monthly	Six monthly	Annually
FILTER CASSETTES Establish filter cassette status by reading the pressure monitor.	X ¹⁾		
BOTTOM SECTION/ DRAINAGE Check that the return oil pipe is not blocked	X ²⁾	X ²⁾	
FAN Check that there is no abnormal noise or vibration			X

¹⁾ The filter cassettes should be checked once a month during the first six months that the filter unit is in use. The service interval can then be adapted accordingly, but inspection intervals must be no longer than six months. Note that when the yellow LED is lit, the inspection interval must take place more frequently as the pressure drop now increases quicker.

²⁾ The bottom section and drainage should be checked once a month during the first six months the filter unit is in use. The service interval can then be adapted accordingly.

10 ELECTRONIC PRESSURE MONITOR

10.1 FUNCTION DESCRIPTION

An electronic pressure manometer A•monitor is supplied as standard along with all A•mist^{10C} filter units.

The pressure monitor is delivered factory preset and contains the following features:

- A** OPTICAL DISPLAY OVER EACH FILTER STAGE
The present pressure drop over each filter stage is monitored:
Filter 1 - Filterstage 1, ie S3B1/595 alt. S3B3/595. See also 11.2.
Filter 2 - Filterstage 2, ie HEPA Filter. See also 11.2
- B** LED INDICATION
A green LED lamp is lit as long as the filter cassette is working within the preset pressure range. When the yellow lamp is lit, call your service contact to replace or wash the filter stage (only valid for filter stage 1). When the red LED lamp is lit, the pressure drop is too high for the filter unit.
- C** HOUR COUNTER DEVICE
An hour-counter device is also included in our standard equipment.
It measures and monitors the operation time in hours for the filter unit.

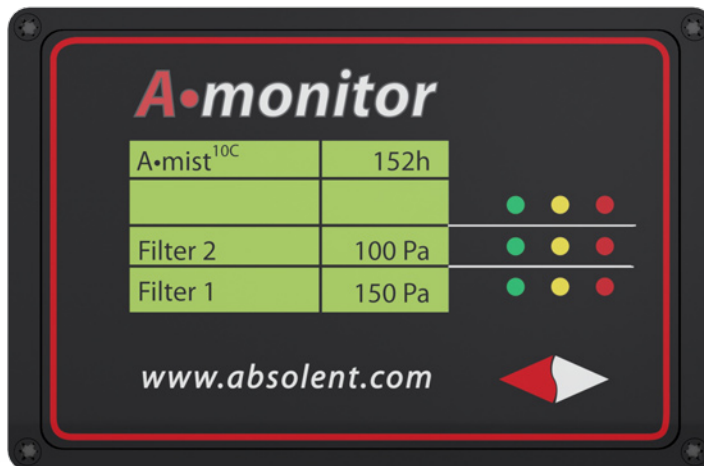

10.2 PRESSURE SETTINGS ELECTRONIC MANOMETER

TYPE		GREEN [Pa]	YELLOW [Pa]	RED [Pa]
A•mist ^{10C}	FILTER 1 (S3B1 or S3B3)	0-500	500-600	600-
A•mist ^{10C} HEPA	FILTER 1 (S3B1 or S3B3)	0-500	500-600	600-
	FILTER 2 (HEPA)	0-600	600-800	800-

PLEASE NOTE!

If a filter stage is used even though the red LED-lamp is lit, the filter unit gives a reduced air volume. Note however, that the filter unit will not be damaged when operated with a clogged filter stage.

Handling during service is described under "Changing the filter".

11 HANDLING THE FILTER CASSETTES



Warning! Use requisite personal protection equipment when performing service work on the filter unit. Lifting aid or the like must be used when carrying out service work above the ground. Since the cassettes are heavy it is important to be on steady ground when replacing filter cassettes.

11.1 GENERAL

Filter cassettes are heavy, especially when filled with fluid after a period of use. Below is a table of weight for the different filter cassettes available. The type designation of the supplied filter cassette can be found on the rating plate located on the front of the filter cassette.

Filter type	Filter cassette type	Weight new cassette (dry)	Weight fluid filled cassette
A•mist ^{10C}	Alt. 1; Filter stage 1: S3B1/595	37.5lb / 17kg	55lb / 25kg
	Alt. 2; Filter stage 1: S3B3/595	37.5lb / 17kg	60lb / 27kg
A•mist ^{10C} HEPA	Filter stage 1: S3B1/595	37.5lb / 17kg	55lb / 25kg
	Filter stage 2: HEPA TRSA-N 595x200	28.7lb / 13kg	28.7lb / 13kg

11.2 FILTER CASSETTE POSITIONING

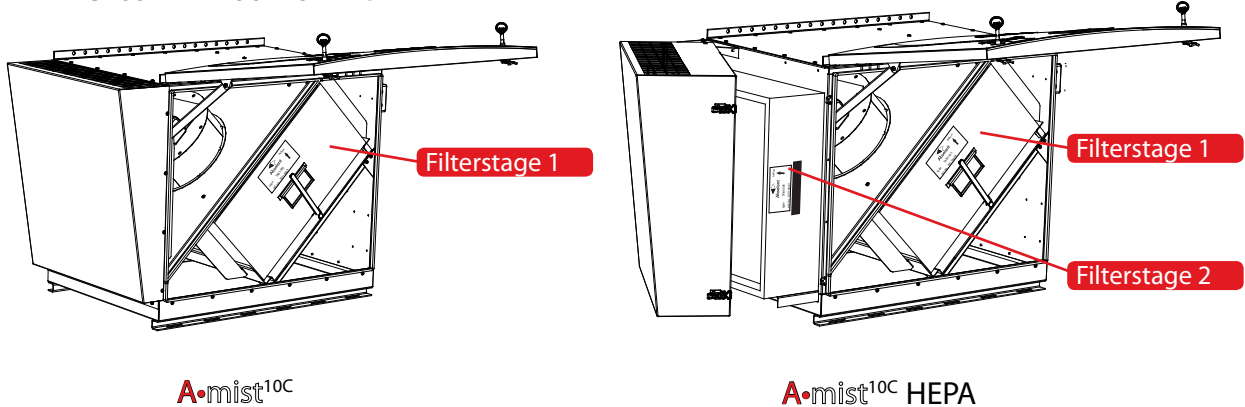

11.3 INSTRUCTIONS FOR REPLACING FILTER STAGE 1



1. Check and note the pressure drop over filter stage 1 when the unit is in operation.
2. Turn off the fan and disconnect the filter unit from electricity.
3. Open the service door by turning the two keys 180° counter-clockwise (see pict. A). Always secure the door by using the safety arm, (see pict. B). Be careful, the door is heavy! If there is oil at the inside of the service door, use a rag to remove it.
4. Loosen the filter cassette by turning the retainer arm as shown in pict. C. Pull out the cassette (see pict. D).
5. Check that the sealing strip on top of the new filter cassette is not damaged. Check that the arrow on the cassettes' mark-up sign is pointing in the air direction (pict. E).
6. Push the new cassette into its position (pict. F) and secure the filter cassette according to pict. C.
7. Close the service door by turning the key clockwise 180° (pict A).
8. Start the fan and check the pressure drop.

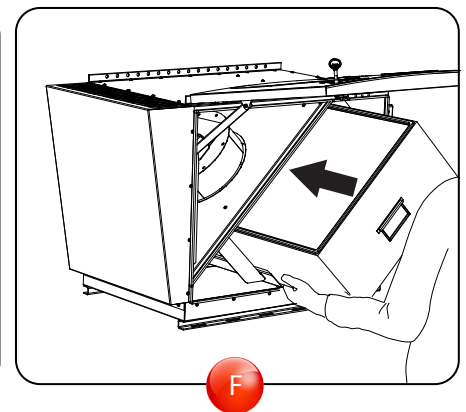
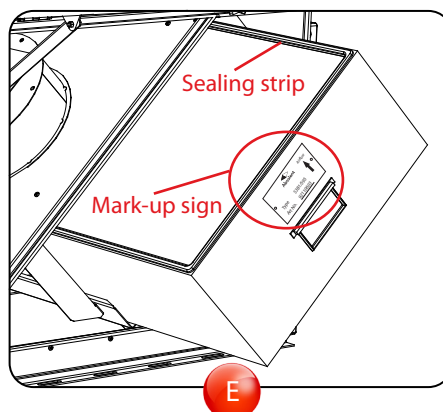
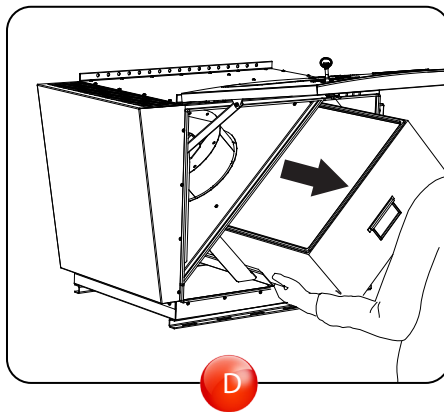
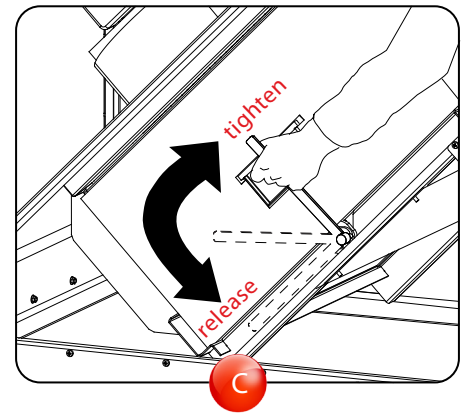
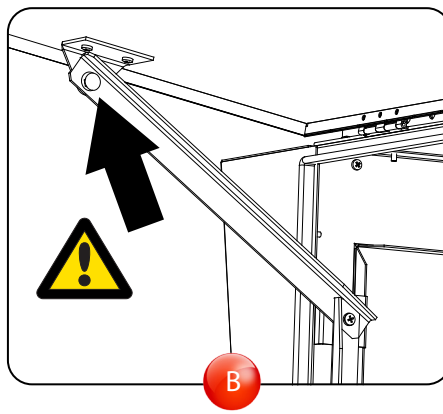
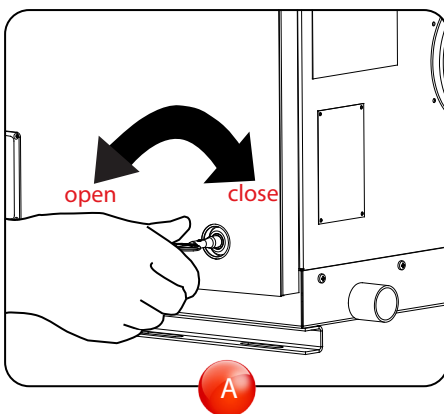

Note! If the supply air has a high content of chips or shavings, inspect and clean the drain opening upstream of the return oil tank/pump more often to prevent it from becoming clogged.



11.4 INSTRUCTIONS FOR REPLACING HEPA filter, IF INSTALLED.

1. Check and note the pressure drop over filter stage 2 when the unit is in operation.
2. Turn off the fan and disconnect the filter unit from electricity.
- 
 3. Open the service door by turning the two keys 180° counter-clockwise (pict. A). Always secure the door by using the safety arm, (see pict. B). Be careful, the door is heavy! If there is oil at the inside of the service door, use a rag to remove it.
4. Loosen the two compression latches and let the hood swing out to the left (pict. C).
- 
 5. Remove the HEPA filter cassette, see pict. D and E.
6. Check that the sealing strip on the new HEPA filter cassette is not damaged before you push it into place. The sealing strip placed on the HEPA cassette must be facing the fan unit (pict. E). Be careful that the compression latch hooks don't harm the HEPA Cassette sealing strip or/ and the HEPA material when changing the cassette. Also make sure that the HEPA cassette inner content isn't touched as this could reduce the separation degree.
- 
 7. Close the hood and tighten the two compression latches. Secure that the hood really compresses the HEPA sealing strip (pict. F).
8. Close the service door by turning the two keys clockwise 180° (pict. A).
9. Start the fan and check the pressure drop.

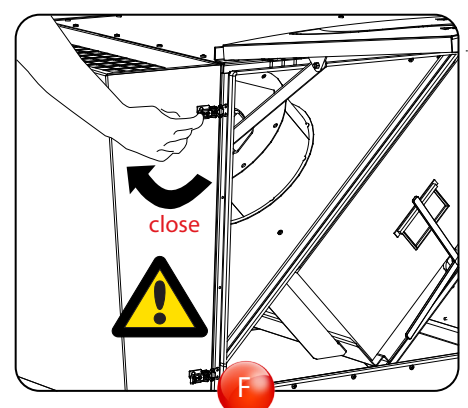
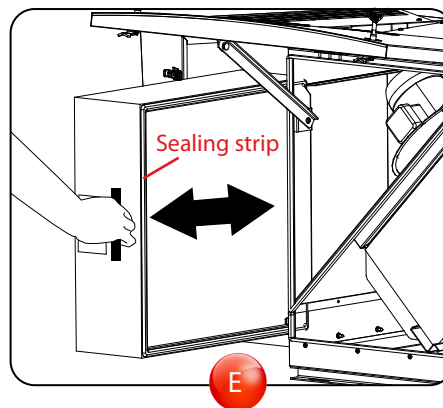
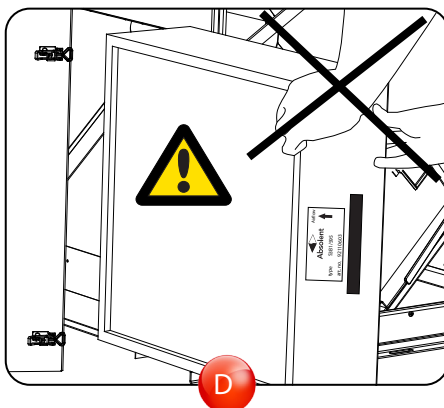
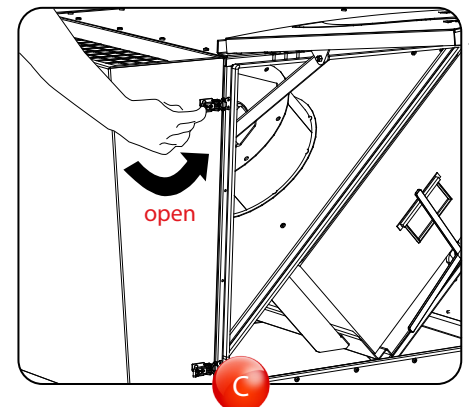
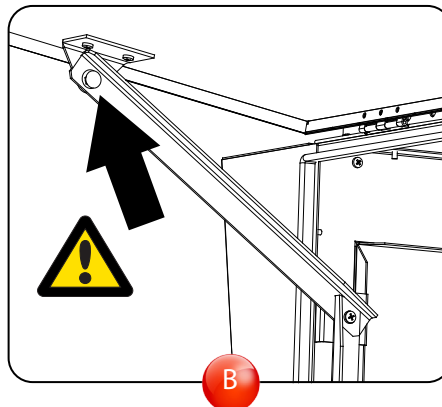
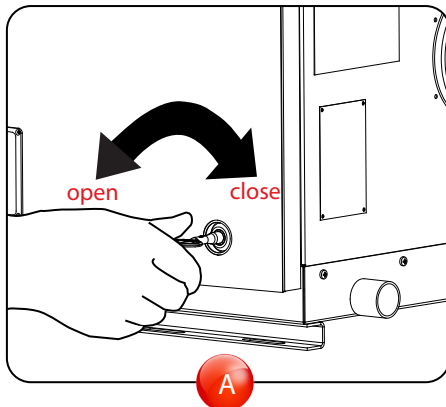

11.5 WORN OUT FILTER CASSETTES

When the filter cassette is worn out it has to be taken care of in an environmental-friendly way.

The sheet metal casing and the aluminum separators can be recycled.

Clean filtermedia can be sent to disposal facilities, but when it contains oil and particles from the process, local regulations for disposal or incineration need to be followed.

If the oil is washed from the cassette, it can usually be sent for landfill.

11.6 TO CLEAN FILTER CASSETTES

Filter stage 1 can be washed several times*). Wash with water-based degreasing agent in a chamber washer (pict. A), max. permissible water temperature: 90°C.

After washing, the filter must be left to dry until it no longer drips before it can be used again (Figure D). The filter continues to dry in the filter unit.

The Absolute filter (HEPA) is not washable and must be replaced when the pressure drop exceeds the "service required" level.

If you do not have a chamber washer, you can place the filter cassette in a tub filled with water mixed with a water-based degreasing agent for 4-8 hours. Remove the cassette from the tub and allow the filter cassette to finish dripping before you flush it clean with a high-pressure washer.

Be careful not to damage the separators when you spray them under high pressure. The result of this cleaning method is doubtful and should therefore be tested from case to case.

Check that the sealing strip is undamaged before you refit the filter cassette. The sealing strip must face upward.

*) Depending on the type of impurities it is exposed to, the useful life of the filter may reduce after washing, when compared with a new filter.

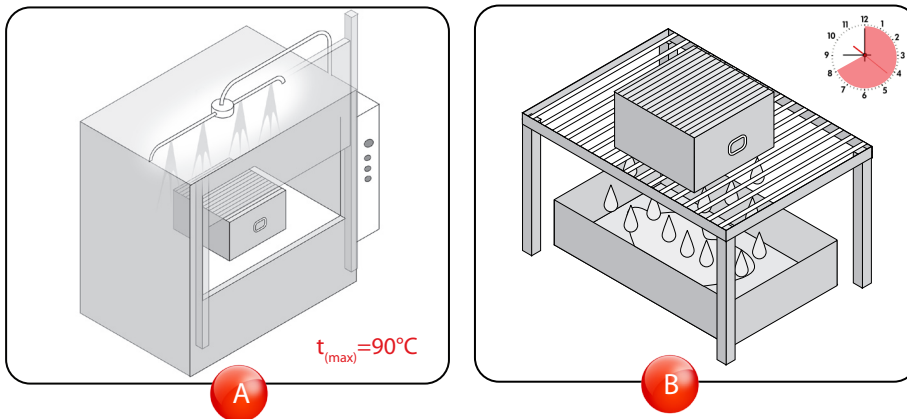

12 ACCESSORIES

A number of accessories are available for the type A•mist^{10C} Absolent oil mist filter. Installation instructions for these are described on the following pages. However, note that the products must be ordered separately.

12.1 WALL MOUNTING BRACKET

The wall mounting bracket is designed for securing the unit to a wall; however it can also be used for securing the unit to the side of a machine.



12.2 CEILING HUNG

4 threaded bars to secure the unit to the inner ceiling.
Max length: 79in / 2000mm, excl filter unit.



12.3 FLOOR STAND

The floor stand is designed for securing the unit to the ground. Floor stand height is: 79in / 2000mm (excl filter unit).



12.4 OUTLET DUCT CONNECTION

The A•mist^{10C} can also be supplied with a outlet duct connection. The connection diameter is \varnothing 7.9in / 200 mm.



12.5 EXTENSION HOOD FOR AFTER-ASSEMBLY OF HEPA

If the filter unit has been delivered without a HEPA filter, it still can easily be retrofitted later on.

A kit consisting of HEPA hood and HEPA cassette can be ordered separately.

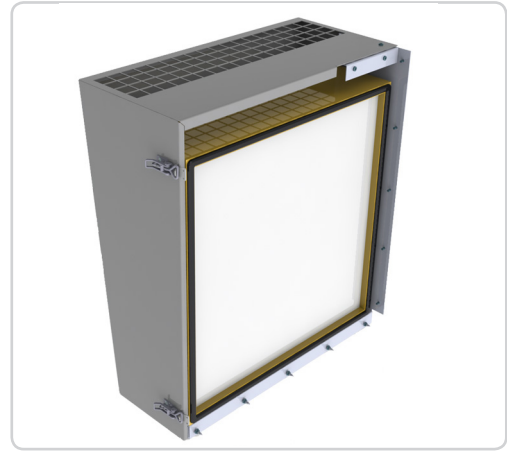

12.6 CARBON FILTER CASSETTE

If the contaminated air contains gas or odours, the HEPA filter stage can be replaced by AFK carbon filter cassettes.

Each cassette measures 23.4x23.4x7.9in / 595x595x200mm and contains 75lb / 34kg active carbon.



12.7 LIQUID TRAP OPTIONS

There are several options for liquid traps to the A•mist^{10C} unit shown below:

12.7.1 LIQUID TRAP - HOSE

The return liquid hose is designed for connection to the return oil pipe of the filter unit.



12.7.2 LIQUID TRAP - PVC

The Liquid trap in PVC is designed for connection to the return oil pipe of the filter unit.



12.7.3 LIQUID TRAP - STEEL BUCKET

The steel bucket liquid trap is designed for connection to the return oil pipe of the filter unit.

The liquid trap steel bucket consists of a tight bucket with a fitted level indicator enabling the operator to see the level of liquid in the bucket.



12.7.4 LIQUID TRAP - RECEPTACLE

The liquid trap is designed for connection to the return oil pipe of the filter unit.

The liquid trap receptacle consists of a tight receptacle that is transparent enabling the operator to see the level of liquid in the receptacle.



12.8 SPRAY SYSTEM

If the extracted particles are "too dry" or if they contain liquid particles with excessive viscosity (sluggish), this drastically reduces the self-cleaning capability and useful life of the filter unit.

To increase the liquid content in the extracted particles and/or reduce the viscosity, small liquid droplets are sprayed from a nozzle into the air.

The liquid added must be able to dissolve the impurities separated in the filter. Water is used for emulsions. The spray nozzle is mounted in the inlet duct of the filter unit.

The spray nozzle is controlled by a time relay with adjustable pause and spray period. For instructions on safety, installation and maintenance, see the separate instructions for use.

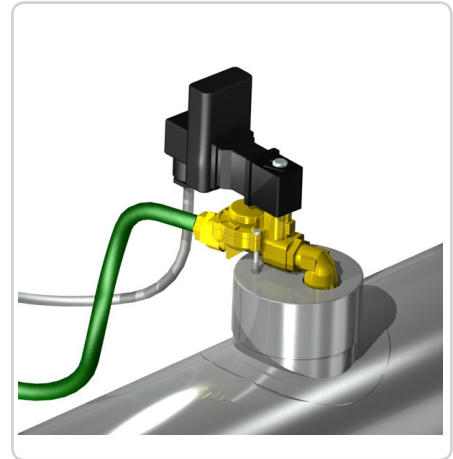

12.9 MOTOR PROTECTION

The A•mist^{10C} filter units with built-in fan can be supplied with a mounted protective motor contactor.



12.10 FREQUENCY CONVERTER

The A•mist^{10C} filter units with built-in fan can be supplied with frequency converter and constant pressure control. Contact your nearest Absolent dealer for more information.



13 FAULT TRACING

Malfunction	Possible cause	Action
Low capacity (air flow)	The fan rotates in the wrong direction.	Check the fan's direction of rotation (only skilled personnel). See heading 13
	With speed (rpm) regulation: The fan speed (rpm) is set too low.	Check the fan speed (rpm) - (only skilled personnel).
	Too high pressure drop over one or more filter cassettes.	Check the pressure drop. If any of the yellow or red LED lamps are lit on the electronic manometer, the filter cassette to which the lamp relates needs to be replaced.
	High pressure drop in the duct system.	Check and possibly change the duct system.
	Adjustable damper is closed or incorrectly adjusted.	Check and possibly adjust the damper on the suction pipe between the machine and filter.
	The ducts are not sealed or dirty.	Check that there is no leakage from the suction pipe between the machine and filter. Check that the ducting doesn't contain dirt.
Abnormally short replacement interval for the HEPA filter:	An incorrectly positioned or damaged sealing strip can result in leakage past filter stage 1, resulting in unfiltered air reaching the HEPA filter.	Check that filter stages 1 and 2 are fitted with the seal pointing upwards. Also check that the sealing strip is undamaged.
	Cassettes that are not secured can result in air leakage past the filter cassettes. Unfiltered air will then reach the HEPA filter.	Check that filter stages 1 and 2 are secured against the sealing frame correctly.
	The filter cassette in stage 1 is not optimised for the application in question.	Check with Absolent that the correct filter cassette is being used in filter stage 1 for the application in question.
Abnormally short service interval for the filterstage 1:	The filter cassette in stage 1 is not optimised for the application in question.	Check with Absolent that the correct filter cassette is used in filter stage 1 for the application in question.
	The filter cassettes have become clogged on account of high viscosity in the oil mist, which gives insufficient drainage.	If emulsions are used, filter clogging may be due to the filter running when production has stopped, which dries out the filter cassette (water evaporates). Consequently, switch off the filter unit when not in use. If the fluid in the process has a high viscosity, it is necessary to apply fluid with a spray system (heading 12.9).
	The filter cassettes have become clogged.	Check that chips have not been drawn down with the air into the filter unit. The problem with chips can be solved by calibrating the air flow or coarse filtering before the filter unit. Also check that sticky particles have not clogged filter stage no. 1 (for example, in foundry applications). Contact Absolent for appropriate measures.

14 CHECKING THE FAN'S DIRECTION OF ROTATION



WARNING - DANGEROUS VOLTAGE
All electrical work must be carried out by qualified electricians.

Make sure that the fan impeller rotates in the correct direction. Since you are unable to see the impeller direction due to the construction, you have to use the electronic manometer instead.

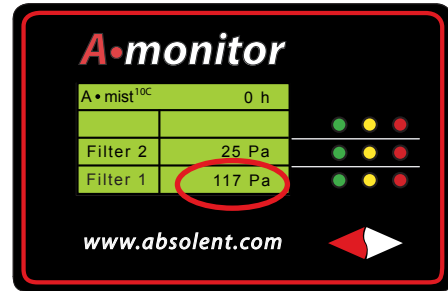
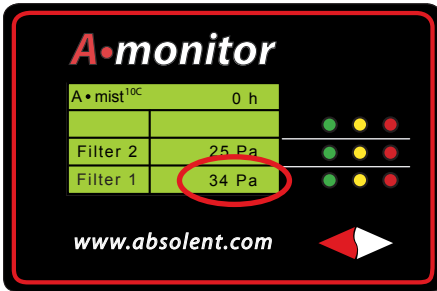

If the pressure drop over the first filter is ≤ 50 Pa, then transpose the two phase leads and restart the fan. Check the filter pressure drop again, to see if it is ≥ 100 Pa. The direction of rotation is then correct.

15 ABSOLENT WARRANTIES

Absolent always take full responsibility that the delivered product fulfils the function and life time guaranteed when purchased. This warranty is however only valid if the product is in its original configuration and only when original spare parts have been used when servicing or repairing the filter unit.

Some examples on why original parts are so important are shown below:

1. FAN MOTOR

In order to cope with the special assembly configuration in an Absolent unit the original motor is supplied with special bearings and a bearing locking device.

Using the "wrong" type of motor will increase the risk of breakdown or failure.

2. FILTER CASSETTES

The Absolent oil mist filter depends on the multi-stage filtration technology. The unit contains one or two filter cassettes. In order to reach the optimum filtration efficiency and the longest possible life time, the filter cassettes have been carefully balanced against each other.

If one or several of these cassettes are replaced by a filter cassette this balance is destroyed and the consequence is decreased collecting efficiency and shortened life time for all filter stages.

16 SPARE PARTS

Absolent has a complete range of spare parts, which ensure the operation of installations.

When asking for spares from your local distributor, please supply the filter unit's serial number and the part number in order to guarantee delivery of the correct spare parts. These can be found on the machine plate, which is located on the right-hand side of the unit. See figure 1.

When ordering filter cassettes, the above details should be supplemented with the filter cassette's material code. This can be read on the filter cassette's rating plate by "type". See figure 2.

 Absolent AB Kartåsgatan 1 SE-53140 Lidköping, Sweden Phone+46 510484000, Fax +46 510484029		
Art.nr. Part No. Art.nr.	11001581	
Benämning Description Bezeichnung	A•mist ^{10C}	
Seriennr. Serial no. Seriennr.	2010XXXX	CE
Spänning Rated Voltage Nennspannung	400	(V)
Frekvens Frequency Frequenz	50	(Hz)
Markström Rated Current Nennstrom	1,20	(A)
Effekt Rated output load Nennleistung	0,55	(kW)
Cost	0,86	(-)

Fig. 1

		Airflow ↑
type	S3B1/595	
art. no.	92110603	

Fig. 2

17 TECHNICAL SUPPORT

Absolent has a complete range of spare parts, which give full service, and ensure the operation of installations. In the event of questions concerning maintenance and spare parts please contact:

HEAD OFFICE
 Absolent AB
 Kartåsgatan 1
 SE-531 40 Lidköping
 Sweden
 Tel +46 (0)510 484000
 Fax +46 (0)510 484029
 E-mail: info@absolent.se
 www.absolent.com

US SALES OFFICE
 Absolent Inc.
 8601 Six Forks Road, Suite 400
 Raleigh, NC 27615
 USA
 Tel +1 (919) 882 2075
 Fax +1 (919) 882 2087
 E-mail: info@absolent.se
 www.absolent.com

CHINESE SALES OFFICE:
 Absolent AB, Mary Li
 Room 615, 6/F CYTS Plaza,
 No.5 Dongzhimen Nandajie, Dongcheng District,
 Beijing 100007
 P.R.China
 Tel: +86 10 5815 6512
 Fax: +86 10 5815 6255
 Email: mary.li@absolent.com
 www.absolent.com

LOCAL DEALER:

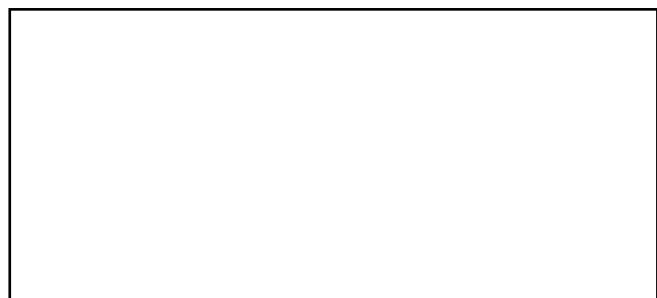

18 EC DECLARATION OF CONFORMITY

Manufacturer:

Absolent AB
Kartåsgatan 1
SE-531 40 Lidköping
Sweden
Phone: +46 (0)510-48 40 00

Authorized to compile technical documentation

Jan Berntsson
Kartåsgatan 1
SE-531 40 Lidköping
Sweden
Phone: +46 (0)510-48 40 00

We, Absolent AB, declare under our sole responsibility that the products:

A.mist^{10C} and A.mist^{10C} HEPA

to which this declaration relates, is in conformity with the following standard(s) or other normative document(s)

Machinery directive	2006/42/EG
Electromagnetic Compatibility (EMC)	2004/108/EG
Low Voltage Directive (LVD)	2006/95/EG

Lidköping , 28th of December 2009



Tony Landh
CEO