

**US**

## User's manual

Oil Mist Filter

- ODF 4000T/TF
- ODF 8000T/TF



# ODF-T



# 1. BASIC INFORMATION

## 1.1 Introduction

This manual contains all necessary information about safety, installation, commissioning and maintenance.

This product is produced and designed in accordance with applicable EC, UL and CSA directives. To preserve this status, this unit must be installed, repaired and maintained by skilled personnel and genuine spare parts must be used.

For advice when technical service or spare parts are needed, contact Absolent Inc. or your nearest authorized dealer. You will find details on who to contact under the heading: "Technical support".

## 1.2 Range of Application

The ODF filter unit is designed for cleaning air containing oil mist only. Use of the filter unit for other applications is not permissible, unless the manufacturer guarantees its proper function.

<b>1</b>	<b>Basic information .....</b>	<b>2</b>
1.1	Introduction .....	2
1.2	Range of Application .....	2
1.3	Contents .....	2
<b>2</b>	<b>EC Conformity Declaration, UL/CSA .....</b>	<b>3</b>
<b>3</b>	<b>List of Warning Signs .....</b>	<b>3</b>
<b>4</b>	<b>Safety Precautions .....</b>	<b>4</b>
<b>5</b>	<b>Transport at Site/Mounting/ Installation .....</b>	<b>5</b>
5.1	General .....	5
5.2	Transporting the Unit at the Site .....	5
5.3	Mounting on floors .....	5
<b>6</b>	<b>Operation / Design .....</b>	<b>5</b>
<b>7</b>	<b>Technical Details, ODF .....</b>	<b>6</b>
<b>8</b>	<b>Electrical Connections .....</b>	<b>7</b>
8.1	General .....	7
8.2	Wiring the Motor for Direct On-line Starting .....	7
8.4	To Check the Fan's Direction of Rotation .....	7
<b>9</b>	<b>Starting the Filter Unit for the First Time .....</b>	<b>7</b>
9.1	Inspection during Initial Start .....	7
<b>10</b>	<b>Care / Maintenance .....</b>	<b>8</b>
10.1	General .....	8
10.2	Service Schedule .....	8
<b>11</b>	<b>Handling the Filter Cassettes .....</b>	<b>9</b>
11.1	General .....	9
11.2	Instructions for Replacing Filter Cassettes .....	9
11.3	Worn Out Filter Cassettes .....	10
11.4	To Clean Filter Cassettes .....	10
<b>12</b>	<b>Accessories .....</b>	<b>11</b>
12.1	Return Liquid Hose .....	11
12.2	Liquid Trap .....	11
12.3	Liquid Trap Receptacle .....	11
12.4	Extension Legs .....	12
12.5	Spray System .....	12
12.6	Motor Protection .....	12
12.7	Frequency Inverter .....	12
12.8	Carbon Filter Cassette .....	12
12.9	Differential Pressure Monitor .....	13
<b>13</b>	<b>Troubleshooting .....</b>	<b>14</b>
<b>14</b>	<b>Spare Parts .....</b>	<b>15</b>
<b>15</b>	<b>Technical Support .....</b>	<b>15</b>



**Read and understand the user's manual before beginning work in the filter unit.**

**US** **2. Conformity Declaration EC / UL / CSA**

Absolent AB declares under its own responsibility that the product, ODF, dealt with in this declaration, meets the following Standards or other regulatory documents:

- Machinery directive: 98/37/EC
- EMC directive: 89/336/EEC in addition to appendices 93/31/EEC and 93/68/EEC
- LVD directive: 73/23/EEC in addition to appendices 93/68/EEC
- UL directive: Electrical components are UL approved
- CSA directive: Units without electrical control equipment and pump are CSA approved







**The CSA approval is solely applicable to ODF Central filters without control and pump equipment.**





**Absolent**  
**Absolent AB**  
 Kartåsgatan 1  
 531 40 Lidköping  
 Sweden  
 2006-03-27



\_\_\_\_\_  
 Tony Landh, CEO





**US** **3. LIST – WARNING SIGNS**

	<p><b>Danger - Read the user's manual</b>                  Read and understand the user's manual before beginning any work in the filter unit. This sign is located on the right-hand side of the filter unit.</p>
	<p><b>Warning - Hazardous voltage</b>                  Only qualified and authorised electricians shall be permitted to install electric wiring in the unit. This sign is located by the electrical equipment cubicle.</p>
	<p><b>Warning - Risk of tipping over</b>                  The filter unit has a high centre of gravity and if improperly handled could tip over. To avoid injury, read the lifting instructions under the heading: "Transporting the Unit at Site/Mounting/Installation". This sign is located on the packaging and on the right-hand side of the filter unit.</p>
	<p><b>Danger – Heavy products</b>                  The filter cassettes are heavy. Check the weight of the relevant filter cassette before handling. Particulars of their weight is located on the rating plate of the filter cassette and under the heading: "Handling the Filter Cassettes".</p>
	<p><b>Danger – Rotating parts</b>                  Consider that the filter unit/and pump can be started up by a timer, remote control or by a metal working machine connected to it. This sign is located on the right-hand side of the filter unit.</p>
	<p><b>Warning - Risk of injury</b>                  Consider that the filter unit can contain hazardous liquids. See the product brochure for the relevant liquid before beginning any work.</p>

Specifications are subject to alteration without prior notice.

3 (15)

**US****4. SAFETY PRECAUTIONS**

Type of warning	Warning text
 Danger	<p><b>Warning – Hazardous voltage!</b> The filter unit operates with hazardous voltage. Electrical installation must be carried out by qualified electrician. Disconnect the power supply to the filter/fan before opening the filter and/or beginning work on the filter/fan.</p> <p><b>Warning – Do not connect the filter unit to a source of explosive gases!</b> Do not connect the filter unit to processing machinery where there is risk of an explosion. The filter unit must not be connected to media that are easily ignitable unless special safety equipment has been fitted to stop the spread of explosion or fire to the filter unit.</p>
 Skilled personnel	<p><b>Caution – Read and understand the user’s manual!</b> Read and understand the user’s manual before beginning work in the filter unit.</p>
 Skilled personnel	<p><b>Caution – Qualified personnel only!</b> All work concerning transporting the unit at the site and maintenance must be carried out by qualified personnel.</p>
 Risk of personal injury	<p><b>Risk of trapping injury!</b> Do not put your hand inside the filter cabinet while the fan is running. Do not wear loose-hanging clothes near the fan while it is running or near rotating shafts. These can be sucked into the fan or get caught.</p> <p><b>Risk of tipping over!</b> Always check the weight of the unit before lifting. The unit’s centre of gravity is relatively high due to position of the fan unit. Before you transport the oil mist filter unit within the site, secure it in an appropriate manner to the transporter or transport it lying in a horizontal position!</p> <p><b>Heavy products!</b> Filter cassettes are heavy. Check the weight of the relevant filter cassette before lifting it. The weight is specified on the rating plate of the filter cassette and under the heading: "Handling the Filter Cassettes". Lifting equipment or the like should be used for servicing and inspection above the floor.</p> <p><b>Risk of slipping!</b> Keep the floor clean. Remove oil spill to prevent injury due to slipping.</p> <p><b>High noise level!</b> If the noise level by the control/workplace exceeds 75 dB(A), wear ear protectors.</p> <p><b>Hazardous liquids!</b> Wear necessary personal protection equipment whenever doing all kinds of service work, since the filter unit may contain hazardous liquids. See the product brochure for the relevant liquid before handling.</p> <p><b>Caution when recirculating air to the room!</b> Note that the standard filter unit does not separate gas molecules.</p>

## US 5. TRANSPORT AT SITE / MOUNTING / INSTALLATION

### 5. General

When unpackaging the filter unit please check that it has not been damaged during transport. If a claim is necessary, contact the shipper.

#### 5.1 Transporting the Unit at the Site



The filter unit is delivered on a wooden pallet and is wrapped in plastic foil. The ODF 4000T and ODF 8000T without fan are delivered fully assembled, the ODF 8000T with fan is split between the filter section and the fan section which have to be assembled at the site. To prevent damage, allow the packaging to remain on the sections until it is time to install them. The filter units have a high centre of gravity. It is therefore important to secure the filter unit properly to the transporter before transporting them. If they need to be lifted, do so according to any of the following methods:

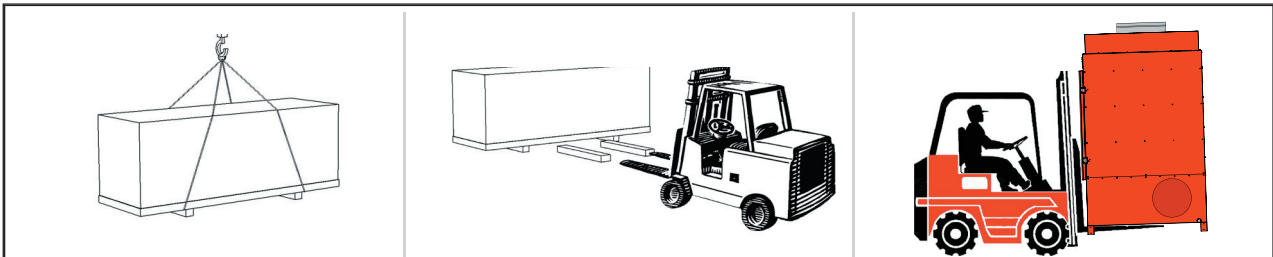

5.1.1 Use an overhead crane to lift the filter unit standing on a wooden pallet.

5.1.2 Use a fork-lift to lift the filter unit standing on a wooden pallet.

5.1.3 Use a fork-lift or an overhead crane to lift a filter unit that is standing.

#### 5.2 Mounting on floors

The floor on which the filter unit is placed must be flat and firm. The floor or base must be designed so that it will support the weight of the filter unit. When installing the filter unit, ductwork, and electric cables, allow sufficient open space in front of the service doors so that they can be opened freely (see figure) and that the interior components such as the filter cassettes can be withdrawn and removed as needed.

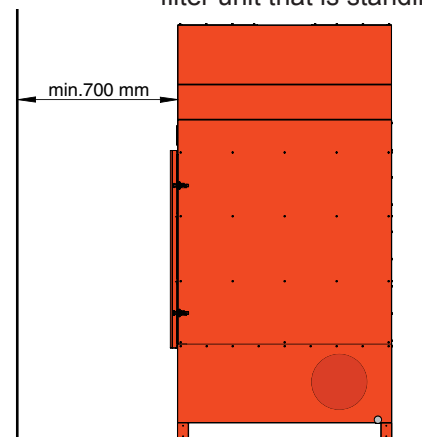

## US

## 6. OPERATION / DESIGN

### ODF

Contaminated air is sucked into the inlet in the lower section of the filter unit and passes through an Absolent filter, where most of the oil particles are collected. The filter becomes saturated with oil, which is drained to the bottom of the unit that serves as a collection vessel. The oil is then conveyed back to the machine, to a receptacle or to a central purification system. The air passes on through another Absolent filter, where the remaining larger particles are collected, and then through a HEPA filter to the fan. By now, the air is usually so clean that it can be returned directly to the premises.

1. Inlet, Pipe connection
2. Filter stage 1
3. Filter stage 2
4. Hepa filter (H13)
5. Fan
6. Diff. pressure gauge
7. Collection vessel & pump (accessory)
8. Outlet

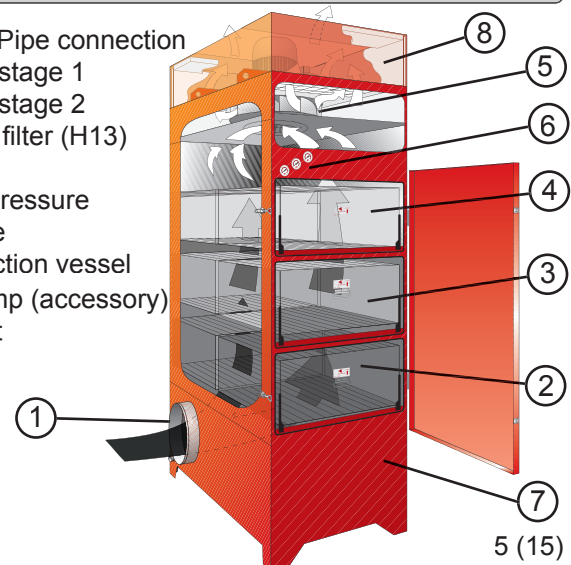

**US** **7. TECHNICAL DETAILS, ODF**

ODF 4000T

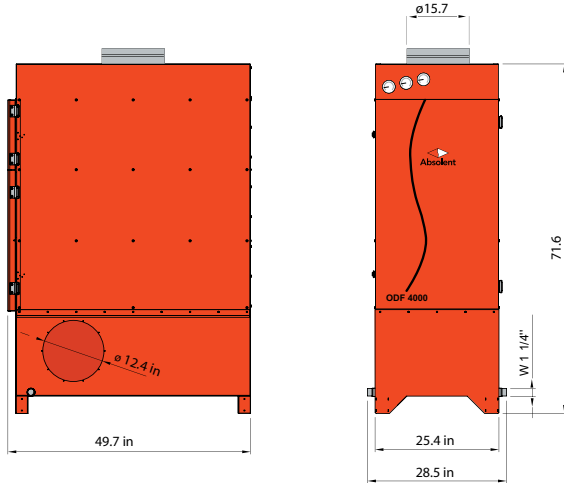

ODF 8000T

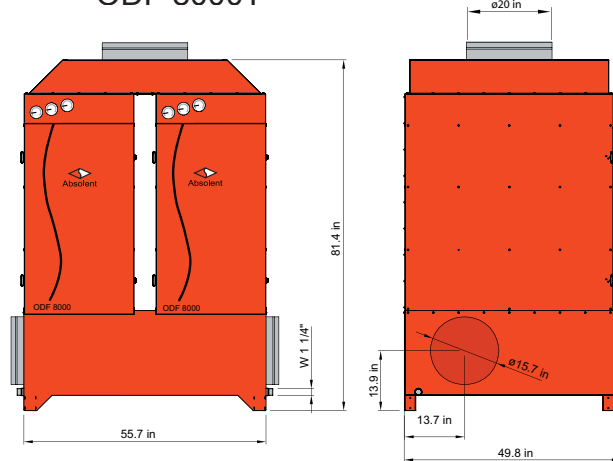

ODF 4000TF

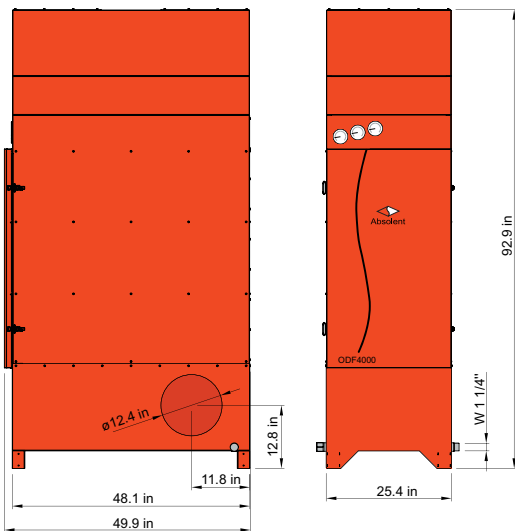

ODF 8000TF

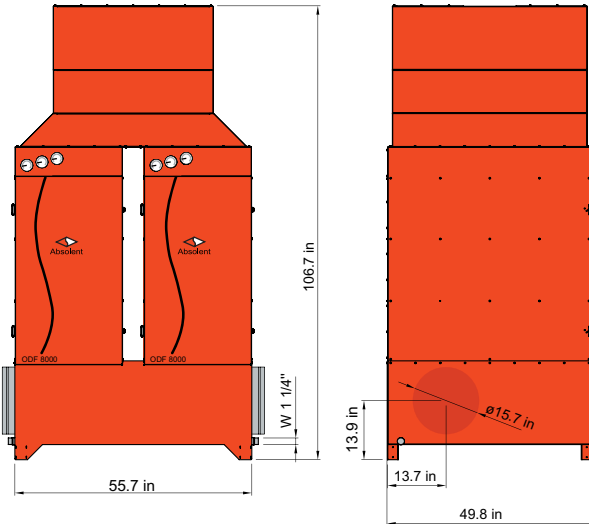

		ODF 4000T	ODF 4000TF	ODF 8000T	ODF 8000TF
Motor output, fan motor	[hp]		5.4		10
Weight with dry filters	[lb]	716	849	1411	1675
<b>Filter cassettes</b>					
Main filter	[Qty]	4	4	8	8
Absolute filter (HEPA)	[Qty]	2	2	4	4
<b>Performance</b>					
Max. airflow	[cfm]	2350	2350	4700	4700
Noise level	dB(A)	1)	70 <sup>2)</sup>	1)	73 <sup>2)</sup>

1) The noise level specified in the user's manual is applicable to filter units with external fan.

2) The noise level specified has been measured at a distance of 1 metre from the filter unit and for a room with an equivalent sound absorption area of 200 m<sup>2</sup>, hemispherical sound propagation.



**US**

## 8. ELECTRICAL CONNECTIONS



### Danger! High Voltage

All electrical wiring must be carried out by a qualified electrician.

### 8.1 General

The standard Absolent ODF 4000TF and ODF 8000TF filter units are supplied without cables from the fan to the motor starter. For the warranty liability to apply, all electrical wiring must be carried out by a qualified electrician in accordance to local regulations. If the filter unit is equipped with extra electrical equipment, this equipment must be wired according to the accompanying wiring diagram.

The Absolent filter units can be customized to suit client specifications. Our range of accessories includes motor starters as well as other peripheral electrical equipment. The most common accessories are described under the heading: "Accessories".

### 8.2 Wiring the Motor for Direct On-line Starting

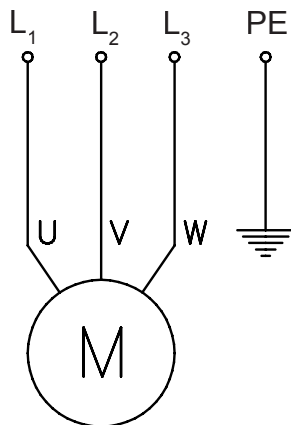

#### Fan motor, standard:

ODF 4000TF: 5.5 hp; 7,8A; 480V; 60Hz

ODF 8000TF: 10 hp; 13,8A; 480V; 60Hz

The electrical details for the fan can be read on the rating plate on the right-hand side of the filter unit.

### 8.4 To Check the Fan's Direction of Rotation

Determine that the fan impeller rotates in the correct direction (counter-clockwise, viewed from the motor side). If you are unable to see the motor while the impeller is rotating, you can start the fan and use the diff. pressure gauge to read the pressure drop across the filter. Then stop the fan and transpose the two phase conductors, restart the fan and read the pressure drop again. The order of phase conductors that enables the fan to generate the highest pressure drop reading is the correct one.

**US**

## 9. STARTING THE FILTER UNIT FOR THE FIRST TIME

### 9.1 Inspection while Initially Starting the Unit

- Check and secure that all the filter cassettes are latched.
- Check and secure that the service door is closed and latched.
- Check and secure that the units exhaust is free from loose items.
- Check and secure the fan's direction of rotation according to 8.4.

**US** **10. CARE / MAINTENANCE**

**10.1 General**

Preventive maintenance and regular servicing will prolong the useful life of your filter unit. This also ensures consistently high cleaning performance in industrial environments. Absolent supplies diff. pressure gauges as standard equipment, one for each filter stage. This facilitates checking the status of the filter cassettes. The diff. pressure gauges are located on the front panel of the filter unit as illustrated below:

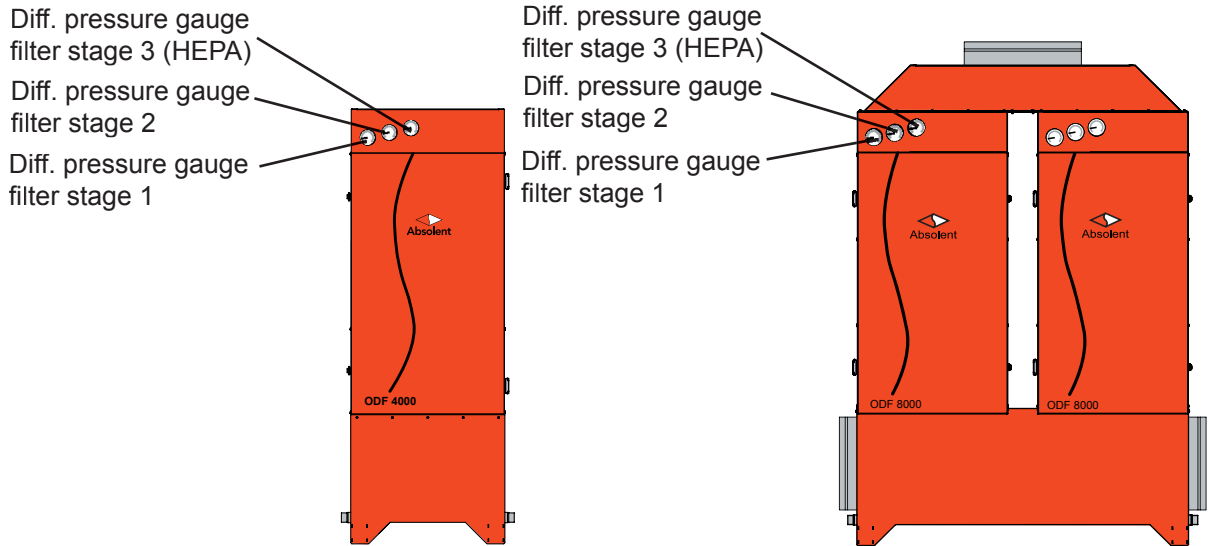

The diff. pressure gauges are calibrated in [Pa] and their dial is divided into green, yellow and orange zones. The cassette of a filter stage should be replaced or cleaned at the latest when the diff. pressure gauge pointer has reached the orange zone. Servicing the filter stages should be planned when the pointer is in the yellow zone. For particulars on who to contact for service see the heading “Technical Support”.

Note, that if the filter unit is operated while one of its diff. pressure gauges are in the red i.e. clogged, the unit will not sustain damage. However the airflow required will not be achieved. The procedure for cleaning filter cassettes is described under “To Replace Filters”.

**10.2 Service Schedule**

	Monthly service	Six-monthly service	12-monthly service
<b>Filter cassettes</b> Read the pressure drop on each diff. pressure gauge	<b>X<sup>1)</sup></b>		
<b>Bottom section / Drain</b> Make sure that the return oil pipe is not clogged	<b>X<sup>2)</sup></b>	<b>X<sup>2)</sup></b>	
<b>Fan</b> Check that there are no abnormal sounds or vibrations.			<b>X</b>

<sup>1)</sup> To familiarize yourself with your newly installed filter unit, inspect the filter cassettes once a month during the first six months of operation. After that period, the service interval can be adjusted to suit that specific unit. The interval should however not exceed 6 months between inspections. Note that if the pressure drop reaches the yellow zone sooner than expected, the inspection interval will have to be shortened since the pressure drop now increases faster.

<sup>2)</sup> To familiarize yourself with your newly installed filter unit, inspect the bottom section and means of drainage once a month during the first six months of operation. After that period, the service interval can be adjusted to suit the specific unit.



**US**

## 11. HANDLING THE FILTER CASSETTES

**Warning!**

Use necessary personal protective equipment when servicing the filter unit. Lifting equipment or the like must be used for service work above the floor.

### 11.1 General

The filter cassettes are heavy, especially if they are filled with liquid after a period in operation. The weights of the various filter cassettes used are tabulated below. You will find the type designation of the filter cassettes supplied on the rating plate on the front of each filter cassette.

Filter type	Type of filter cassette	Weight of a new cassette, (dry) [kg]	Weight of cassette filled with liquid [kg]
ODF central filter	Stage 1: S3/595	19 kg	34 kg
	Stage 2: S3B1	19 kg	34 kg
	Stage 3: HEPA TRSA-N 595x292	12 kg	

### 11.2 Instructions for Replacing Filter Cassettes, ODF Central filter

1. Read and write down the pressure drop across the various filter stages.
2. Switch off the fan (Isolate the power supply with the safety switch).
3. Open the service door.
4. To replace Filter cassettes: Unfasten the cassettes by releasing the two tensioning arms (Figure A)
5. Remove the filter cassettes that show a pressure drop reading higher than the "service required" level specified under "Care and Maintenance" (Figure B) (each tensioning arm secures two filter cassettes, See the Description of the Functions, page 3. Before replacing Filter Stage 1, check the bottom of the filter unit and clean if necessary.
6. Check that the sealing strip is undamaged before you push in the new filter cassette.(Figure C). The sealing strip should face upwards.
7. Fasten the filter cassette (Figure D) by latching the two tensioning arms. Close the service door.
8. Start the fan and check the pressure drop.

**IMPORTANT! If the supply air contains a considerable amount of chips and shavings, check and clean the oil drain outlet in the bottom section often to prevent clogging.**

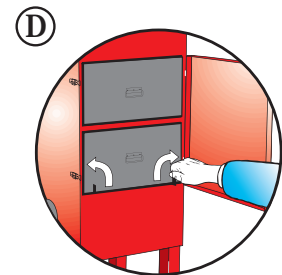
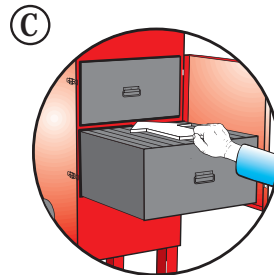
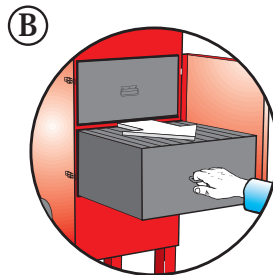
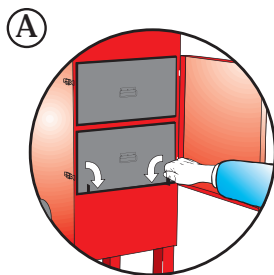

### 11.3 Used Filter Cassettes

A used filter cassette contains oil which in most locations is considered as hazardous waste. Therefore the oil needs to be removed by washing before it is possible to dispose or recycle the cassette in an environmental safe way. Note that the washing liquid also is considered as hazardous waste. After cleaning, the cassettes can be pressed together and shipped to a disposal facility or they can be dismantled. The sheet-metal casing and the aluminium separators can be recycled. The filter medium can be sent to a disposal facility or for incineration depending on local regulations.

### 11.4 To Clean Filter Cassettes

Filter cassette No. 1 (lowest) and No. 2 (centre) can be washed several times\*). Wash with water-based degreasing agent in a chamber washer (Figure C), max. permissible water temperature: 90°C.

After washing, the filter must be left to dry until it no longer drips before it can be used again (Figure D).

Filter No. 3, the HEPA filter, is not washable, and must be replaced when the pressure drop exceeds the "service required" level (orange zone on pressure gauge).

If you do not have a chamber washer, you can place the filter cassette in a tub filled with water mixed with a water-based degreasing agent for 4-8 hours. Then allow the filter cassette to finish dripping before you flush it clean with a high-pressure washer. However be careful not to damage the aluminium separators when you spray them under high pressure. The result of this cleaning method is unsure and should therefore be tested from case to case.

Check that the sealing strip is undamaged before you refit the filter cassette.

The sealing strip must face upward.

\*The useful life of the filter may vary after washing from comparable to a new filter to reduced, depending on the type of impurities it is exposed to.

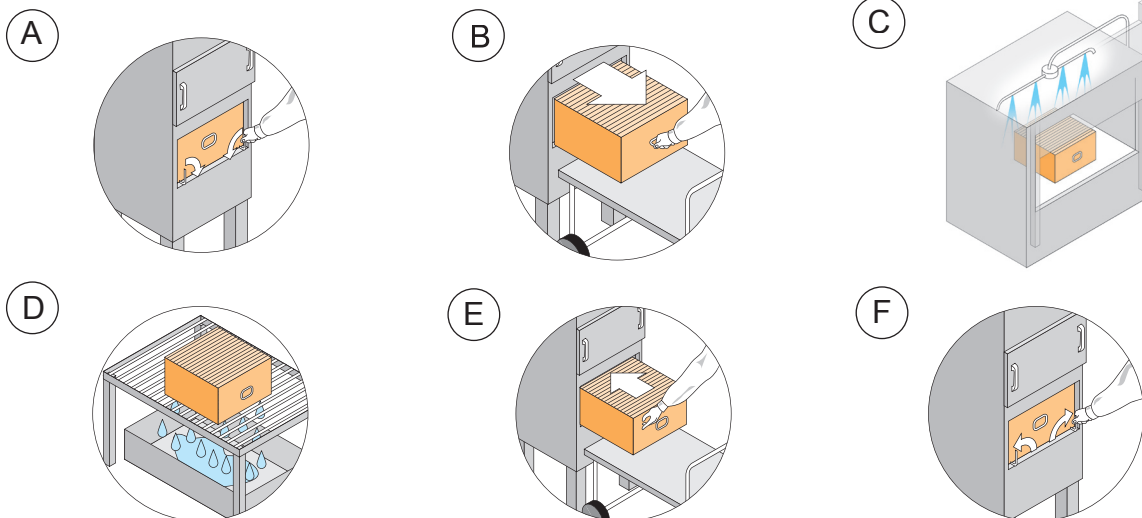

**US**

## 12. ACCESSORIES

A number of accessories are available for the type ODF Absolent oil mist filter. Installation instructions for these appear on the pages that follow. However, keep in mind that the products must be ordered separately.

**US**

### 12.1 Return Liquid Hose

The return liquid hose is designed for connection to the return oil pipe of the filter unit.

The outlet of the liquid trap should not discharge liquid in such a way that the liquid could damage adjacent building elements. Since the fans suck in air through the filter media and generate sub-atmospheric pressure inside the filter unit, correct installation of the liquid trap is extremely important. It must fit tightly against the filter unit and the outlet must be lower than the liquid level.

**US**

### 12.2 Liquid Trap

The liquid trap is designed for connection to the return oil pipe of the filter unit.

The outlet of the liquid trap should not discharge liquid in such a way that the liquid could damage adjacent building elements. Since the fans suck in air through the filter media and generate sub-atmospheric pressure inside the filter unit, correct installation of the liquid trap is extremely important. It must fit tightly against the filter unit and it must be filled with liquid.

**US**

### 12.3 Liquid Trap Receptacle

The liquid trap is designed for connection to the return oil pipe of the filter unit.

The liquid trap receptacle consists of a tight receptacle that is transparent enabling the operator to see the level of liquid in the receptacle.



**US**

## 12.4 Extension Legs

Used when it is desirable to raise the filter unit above floor level to enable the use of a liquid trap, for instance.

The standard legs raise the filter unit 300 mm above the floor.

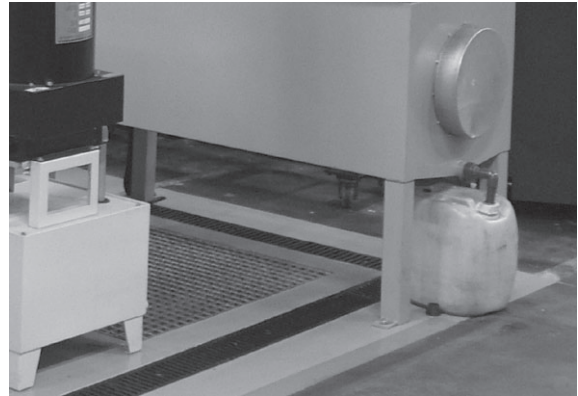
**US**

## 12.5 Spray System

If the impurities are "too dry" or if they contain liquid particles with excessive viscosity (sluggish), this drastically reduces the self-cleaning capability and useful life of the filter unit.

To increase the liquid content in the impurities and/or reduce the viscosity, small liquid droplets are sprayed from a nozzle into the air.

The liquid added must be able to dissolve the impurities separated in the filter. Water is used for emulsions. The spray nozzle is mounted in the inlet duct of the filter unit.

The spray nozzle is controlled by a time relay with adjustable pause and spray period. For instructions on safety, installation and maintenance, see the separate instructions for use!

**US**

## 12.6 Motor Protection

The ODF filter units with built-in fan can be supplied with a mounted protective motor contactor.

**US**

## 12.7 Frequency Converter

The ODF filter units with built-in fan can be supplied with frequency converter and constant pressure control. Contact your nearest Absolent dealer for more information.

**US**

## 12.8 Carbon Filter Cassette

If the contaminated air contains gas or odours, the particle filter stage can be replaced by AFK carbon filter cassettes.



## 12.9 Differential Pressure Switch

### General

The type DTV-2000 and DTV-5000 Differential pressure switches are designed to indicate high pressure drop across the Absolent filter cassettes.

The pressure switch can be equipped with LED (24V), and be supplemented with a lamp that indicates when a change of filters is necessary.

It can also be used to transmit a potential-free signal. This signal can then be fetched on the machine operator's computer monitor or be transmitted to a central maintenance department.

### Operation

The pressure in the tube connected to P1 is compared with the pressure connected to P2. When the differential pressure exceeds the preset set point, the contact switches over.

A knob behind the cover can be used to preset the set point. The knob setting is visible from outside through the cover. The factory-preset switching differential is permanent.

### Design

The pressure switch consists of a fibre glass reinforced plastic sensor housing fitted with a diaphragm made of synthetic material. The differential pressure influences the spring-suspended diaphragm which is linked to a changeover contacts.

1. Angle bracket
2. Diaphragm
3. High pressure connection, P1
4. Low pressure connection, P2

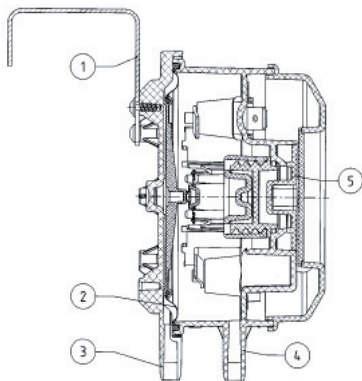

### Technical details

Type: DTV-2000 and DTV-5000  
 Adjusting range: DTV-2000: 500-2000 Pa  
 (DTV-5000: 1000-5000 Pa)  
 Contact data: 1A, 250 VAC, changeover contact  
 Switching differential: See above  
 Electrical connections: Screw terminal, PG11 lead-through  
 Ambient temp.: -20...+85°C  
 Storage temp.: -40...+85°C  
 Max. permissible differential pressure: 5000 Pa  
 Pressure connections: Nipplar för slang med invändig  $\varnothing 6$ mm  
 Material, sensor housing: Glass fibre reinforced plastic material  
 Material, diaphragm: Silicon LSR  
 Angle bracket: Galvanized sheet steel, two 5 mm dia. fastening holes, 40 mm between the centres  
 Degree of Protection: IP54  
 Weight: 0,12 kg  
 CE: The product conforms to the provisions of the European LVD Standard IEC669-1 and IEC669-2 and is CE-labelled.

### Installation Position

Vertical installation is recommended (factory calibrated)

### Dimensions and Wiring

The cover is secured by only one retaining screw making installation and service simpler.

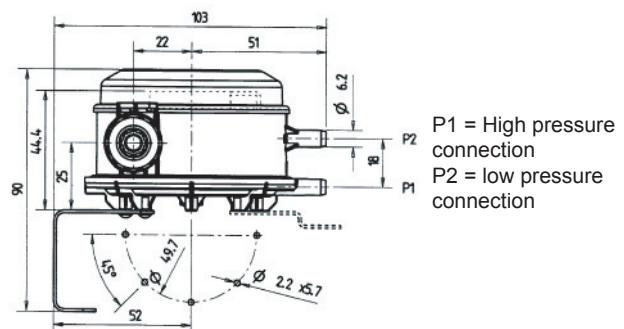
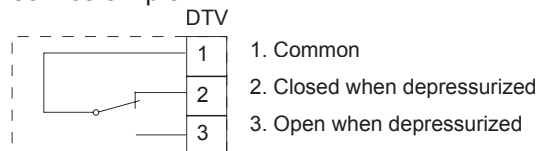





## 13.TROUBLESHOOTING

Malfunction	Possible cause	Remedial measure
<b>Low capacity</b>	The fan rotates in wrong direction.	Check the fan's direction of rotation. See 8.4 <b>(by qualified personnel only)</b>
	Speed control: The fan speed is set too low.	Check the fan speed <b>(by qualified personnel only)</b>
	Excessive pressure drop across one or several filter cassettes.	Check the pressure drops. If the pointer of any of the diff. pressure gauges is in the yellow zone, the filter cassette should be replaced. Compare with the maintenance schedule. See 10,1 - 11,4
	The adjustment dampers are closed or are incorrectly set.	Check dampers, if any, on the suction duct between machine and filter unit.
	The ducts are not tight.	Check that there is no leakage from the suction duct between machine and filter unit.
<b>Abnormally short HEPA replacement intervals:</b>	Incorrectly fitted or damaged sealing strips can cause leakage past the filterstage 1 and/or filterstage 2. This allows unfiltered air to reach the HEPA filter.	Check that all filterstages and the HEPA filter are mounted with the gasket facing upward. Also check that the sealing strip is not damaged.
	Improperly secured cassettes can be the cause of air leaking past the filter cassettes. Unfiltered air can then reach the HEPA filter.	Check that all filterstages and HEPA filter are properly secured against the sealing frame. For further particulars, see under heading 11 "Handling the Filter Cassettes".
	The filter cassettes in filter stage 1 and/or filter stage 2 are not optimized for the current application.	Check with your Absolent supplier to get the "correct" filter cassettes for the current application.
<b>Abnormally short service intervals for filter-stage 1 and/or 2</b>	The filter cassettes in filter stage 1 and/or filter stage 2 are not optimized for the current application.	Check with your Absolent supplier to get the "correct" filter cassettes for the current application.
	The filter cassettes have become clogged due to high viscosity that causes inadequate drainage.	If emulsion is used, the high viscosity may be because the filter unit is operating when production is stopped. This dries out the filters (the water evaporates). Therefore switch off the filter unit when it is not used. If the liquid used in the process has high viscosity, it may be necessary to add liquid with a spray system (see accessories).
	The filter cassettes have become clogged.	Check that shavings are not drawn with air into the filter unit. The problem with shavings can be solved by calibrating the airflow or by rough filtering upstream of the filter unit. Contact Absolent! Also check that sticky particles have not clogged filter stage No. 1 (for example in foundry applications). Contact Absolent for advice!



**US** **15. SPARE PARTS**

Absolent offers a complete range of spare parts. To ensure reliable performance of the Absolent unit, original spare parts shall be used when a part is replaced.

When ordering a spare part the spare part name and part number (if available) shall be supplied to your Absolent dealer. For the purpose of quality assurance (the correct part to the correct unit) the serial number and part number of the filter unit to which the spare parts are intended shall also be provided. When ordering filter cassettes the type number and art. number, i.e part number according to the rating plate (see figure 2) on the front face of the filter cassettes shall be provided.

The serial number and part number of the complete filter unit shall also be included.

You will find these numbers on the rating plate on the right-hand side of the filter unit. See Figure 1.

When ordering filter cassettes, besides the serial and part numbers, you should also specify the material code of the filter cassette. You will find this code on the rating plate of the filter cassette. See Figure 2.

Absolent AB Förhållanden 1 SE-53163 Långåker, Sveden Phone+46 510484000, Fax +46 510484029		
Art.nr. Part No. Art.nr.		
Benämning Description Bezeichnung		
Serienr. Serial no. Serienr.		CE
Spänning Rated voltage Nennspannung		(V)
Frekvens Frequency Frequenz		(Hz)
Mikroström Rated current Nennstrom		(A)
Effekt Rated output load Nennleistung		(kW)
cos. φ		(-)

Figure 1

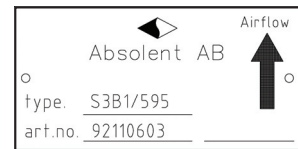

Figure 2

**US** **16. TECHNICAL SUPPORT**

Absolent offers you a complete range of spare parts and full service. This ensures reliable performance in your installation.

**Main Office**  
Absolent Inc  
8601 Six Forks Road, Suite 400  
Raleigh, NC 27615  
USA  
Telephone: +1 (919) 562 0502  
Fax: +1 (919) 882 2087  
Website: www.absolent.com

**Dealer:**