



A•mist^{6C} Compact Oil Mist Filter

The Absolent type A•mist Oil mist filter features one of the most effective systems in the world for cleaning oil mist. The compact filter unit A•mist^{10C} is designed for air flows up to 355cfm. The filter unit can be installed close by or on top of the metalworking machine and is thus especially suitable where floor space is restricted.

The highest possible collecting efficiency.

The filtered air becomes so clean that it usually can be returned to the premises. This means less loss of energy and a more balanced ventilation.

Extremely low maintenance.

Absolent filter units can usually run for at least one year without requiring a filter change. In the majority of applications, Absolent filter cassettes are washable*. This results in a low total cost of ownership.

A very reliable filter unit.

The fan, as the only moving component, is placed at the clean-side to minimize wear & tear as well as vibrations.

Extremely low noise level for agreeable working conditions.

*This does not include HEPA filters.

Centrifugal fan, 0.55hp, positioned between the filters for low sound emission

Filter stage 2
HEPA / Absolute filter with 99.99% collecting efficiency

Filter stage 1
Self-draining
Absolent filter

Inlet duct

Return oil pipe for drained liquid

Return oil tank

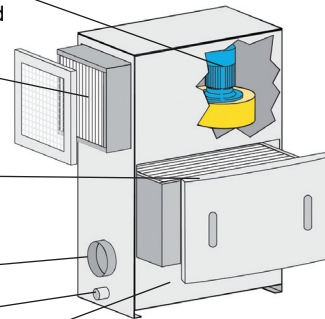

A•mist^{6C}

Operation

The filtering process occurs in two stages. The first stage consists of the self-draining Absolent filter, in which up to 90% of the oil mist is arrested. The second stage consists of a HEPA filter, which has a guaranteed and consistent collecting efficiency of 99.99% arresting 0.3µm dia. particles. Every filter stage has a pressure gauge that indicates when a filter needs to be changed or washed. Thanks to the continuous draining of the filter cassettes, the unit can be operated without interruptions. The return oil is collected at the bottom of the filter for recycling.

Range of Application

The Absolent A•mist^{6C} is well suited for use in applications such as:

- Grinding (cutting fluid emulsion)
- Turning (cutting fluid emulsion)
- Milling (cutting fluid emulsion)
- Electrical discharge machining
- Machining using neat oil and moderate loads

Design

A•mist^{6C} occupies a minimum of space either on the floor or on top of the metal working machine. It has a highly robust design and is supplied with a baked powder painted finish that adds colour to the shop floor.



A•mist^{6C}

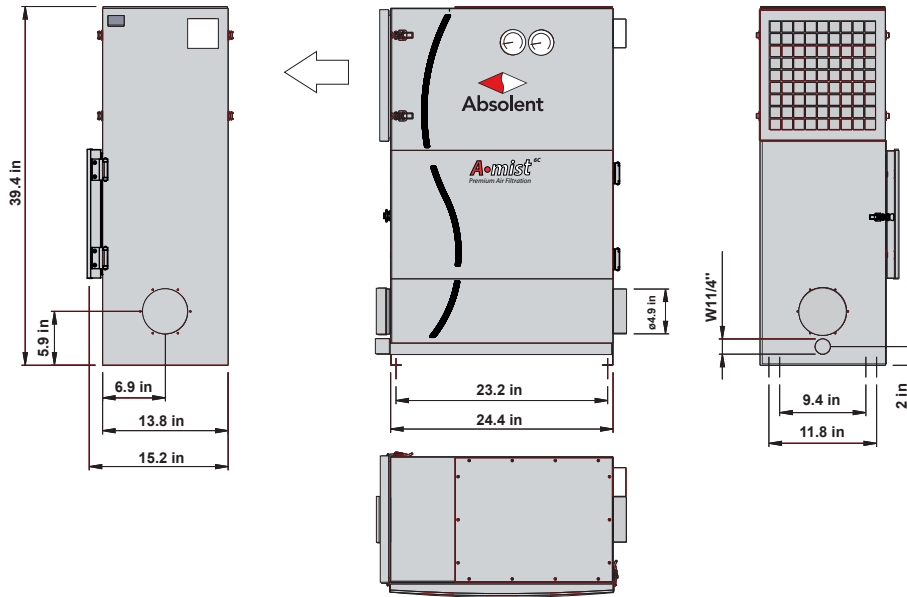

Technical Data		A•mist ^{6C}
Max permissible air volume	[cfm]	355
Sound level, 1m in front of filter unit ¹⁾	[dB(A)]	65
Weight (dry filters)	[lbs]	143
Filter area, filter 1 (Absolent filter)	[ft ²]	83
Filterarea filter 2 (HEPA filter)	[ft ²]	73
Fan Data		
Motor output	[hp]	0.85
Power supply	[A]	1.26
- Rated current (3-Phase)	[V]	440-480
Speed	[rpm]	2400

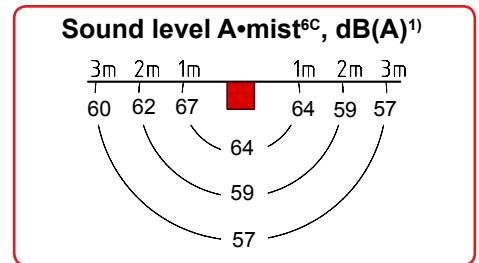

¹⁾ Sound absorption in premises=2153ft², Hemispherical sound propagation. For sound calculation concerning a specific room, contact us at Absolent or any of our dealers.

Standard equipment

- ● RAL 7035 fine structure
Other colours on request!
- Pressure gauges for reading the pressure drop across the filter

Accessories

- Motor starter for fan. Either a manual or protective motor contactor (for automatic or external starting)
- Duct connection for various types of steel or plastic ductwork available on the market
- Water trap for various connections of the return oil pipe
- Pressure monitor, for external alarm or alarm indication with LED
- Special colours

Unique filter cassettes

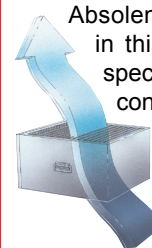

Absolent is one of few companies in this line of business that has specialized in the filtration of air containing wet particles.

This has given us the opportunity to develop a filter cassette that offers a long useful life with consistently high separation efficiency.

Absolent Inc.
8601 Six Forks Road, Suite 400
Raleigh, NC 27615
USA
Phone: +1 (919) 882 2075
Fax: +1 (919) 882 2087
E-mail: info@absolent.com
Sweden • USA • China



Dealer: